

Types, Examples and Working Mechanism of Rheo-Improvers Lubricating Oil Additives

Rasha S Kamal*

Department of Petroleum Applications, Egyptian Petroleum Research Institute, Nasr City,
P.O. Box 11727, Cairo, Egypt

***Corresponding author:** Rasha S Kamal, Department of Petroleum Applications, Egyptian
Petroleum Research Institute, Nasr City, P.O. Box 11727, Cairo, Egypt, Tel: +2 02 22745902
(2155); Email: dr.rasha_samir@yahoo.com

Mini Review

Volume 2 Issue 2

Received Date: June 10, 2018

Published Date: June 22, 2018

DOI: 10.23880/ppej-16000162

Abstract

Lube oil additives play an important role to facilitate our daily life. And the most important one is Rheo-Improve lubricating oil additive, because it is performance enhancing additive it consists of two type viscosity index improvers and pour point depressants. This mini review highlights of Rheo-Improvers importance. Viscosity modifier (preparation of some examples, general properties, working mechanism and factors that limit their action). Pour point depressants (examples, general properties, working mechanism).

Keywords: Rheo- improvers; Viscosity index improvers; Pour point depressant

Introduction

The major role in the science is how to make life so easy and eco-friendly. Lubrication is a feature of how to live an easy life. Lubrication in simply form is the use of material to improve one surfaces over another by using lubricant. Lube oil additives are chemical components or blend used at a specific treat rate, generally from 1 to 35 % of the oil volume, depending on the machine to provide one or more functions in the fluid. Some additives impart specific property to the base oil or suppress undesirable base oil properties and finally others enhance existing base oil properties. Lubricant is additive with oil mixed together to give very good efficiency and save the metal from friction and wear. There are many type of additives and today we will take about an important one (Rheo-improvers).

According to new classification of lubricating oil additives which depending on the working function the additives classify into 3 major category:

1. Rheo- improvers
2. Maintainers
3. Tribo-improvers

Rheo-Improvers (Rheological Properties Improvers)

Rheo-Improvers are responsible for fluidity of base oil. They contribute mainly under hydrodynamic conditions to the lubrication performance by changing or modifying the bulk properties of the liquid. They are lubricating performance additives. Rheological Properties Improvers could be categorized as tribo-improvers "indirect" between regimes of hydrodynamic and mixed lubrication [1].

Viscosity Modifier

The most important property of the oil is viscosity. Formerly, viscosity modifier (VM) which can called also viscosity index improvers (VII) that reduce the rate of viscosity change with temperature. It is one of the

performance additives engine lubricants. The bulk properties are dependent on the structure of the base fluids [1]. Structural features of VM are polymers and copolymers [2-9].

Examples [10]:

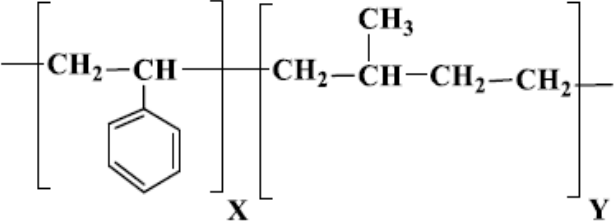
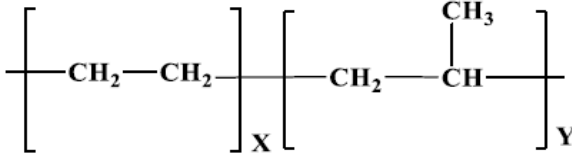
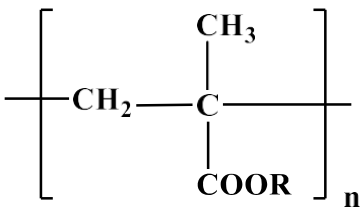
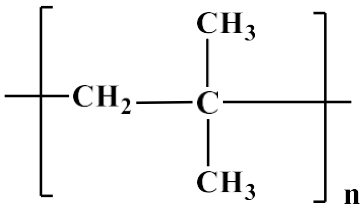
Some Examples of Viscosity Modifiers	Chemical Structure
SIP: styrene-co- isoprene	 <p style="text-align: center;">SIP</p>
OCP: olefin copolymers and the major classes are poly alkyl methacrylate and poly isobutylenes.	 <p style="text-align: center;">OCP</p>
	 <p style="text-align: center;">Polyalkylmethacrylate</p>
	 <p style="text-align: center;">Poly Isobutylenes</p>

PMA : polymethacrylates preparation

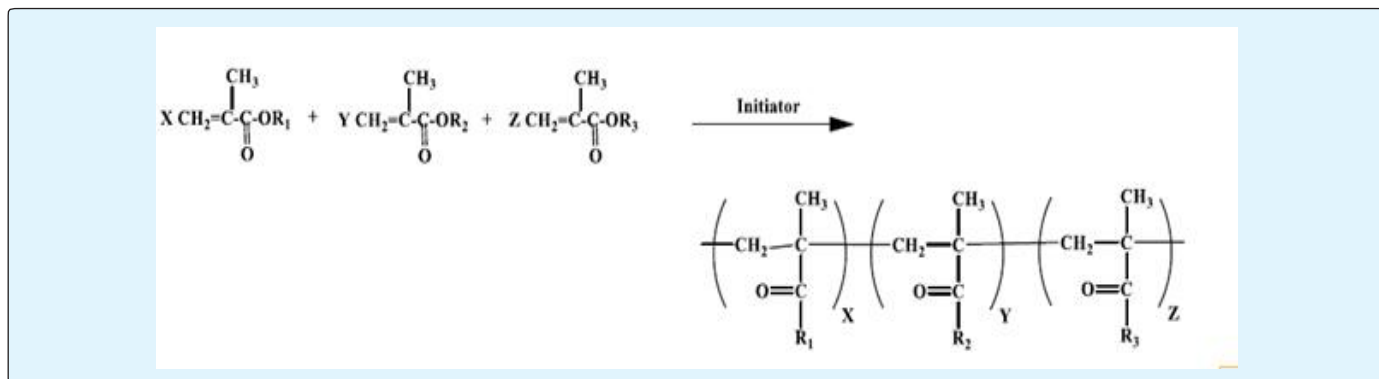

Preparation of Terpolymers as Viscosity Modifier

SPE: Styrene Poly Ester

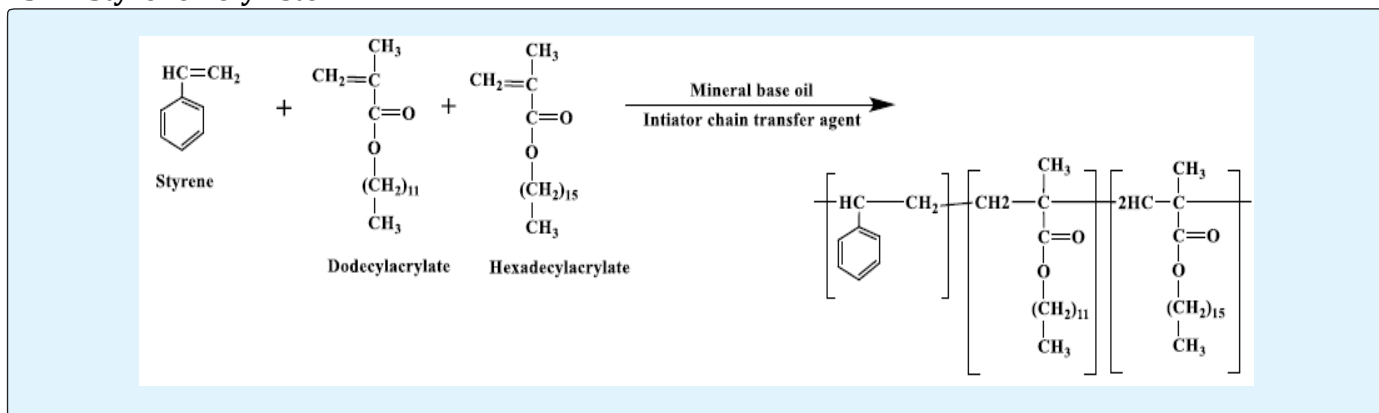

This terpolymer in hexadecyl acrylate 70%, styrene 10% and dodecyl acrylate 20% give very good result as viscosity index improver 145 viscosity index [11].

Mechanism of Viscosity Index Improver: Polymers molecules expands as the temperature is raised, due to the

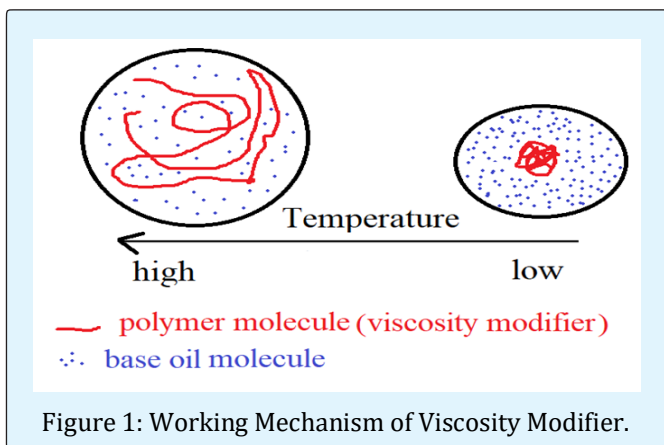

increase in the solvation power, this increasing in size of the micelle counterbalance the reduction of the viscosity of the lube oil due to increasing temperature [12-14], so VM decreases the changes of viscosity with temperature of the mixture [1] (Figure 1).

General Properties of Viscosity Modifier: These additives are expected to satisfy the following general requirements:

1. Oxidation stability and absence of corrosive action;
2. Thermal stability (due to the viscosity modifiers are polymer so to make degradation need trace of peroxides catalyst not affect by temperature);
3. Compatibility with other additives present in the oil [10]

Factors that Limit the Action of Viscosity Modifiers

1. Nature of the base oil (chemical structure of base oil);
2. Concentration of the additive (an optimum concentration);

- Molecular weight of the additive (increase the molecular weight increase the efficiency as viscosity modifier until limited weight);
- Polymer composition (effect of the substituted radical, R);
- Pressure (due to relationship between the pressure and temperature) [10, 2].

Pour Point Depressants

Pour point depressant is one of the performance additives engine lubricants [10]. The pour point is defined as enable lubricant to flow at low temperatures. The pour of an oil has been considered for a long time as the principal properties affecting the cold starting of an engine. At very low temperature the oil freeze (oil cannot pour or flow) that causes damage to the machine elements and although uses the pre-heating system but loose time and energy [1]. The reason of pour less is after refining and get lubricating oil there are fine wax crystals in the mineral oil which accumulate together under low temperature and make a lattice interlocking network which absorb the oil and prevent its pour or flow, so here appear the important of pour point depressant [15-24].

Structural features of pour point depressant (PPD) are polymers can be used to interfere with wax crystal growth and alter the formation of the interlocking network for examples:

Examples

Polymethacrylates at Concentration of 0.1 to 0.5%

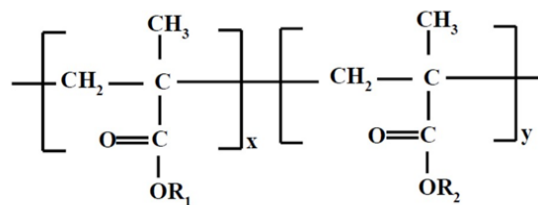

PMA

Alkylated wax naphthalene

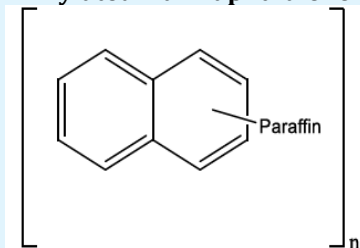

Long Chain Alkyl Phenols (Tetra Paraffin Phenol)[10]

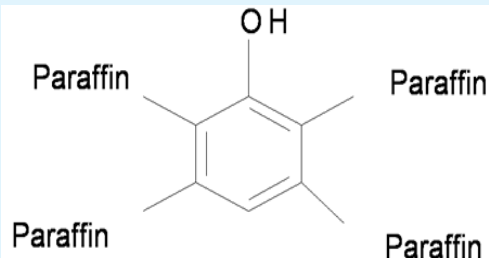

Di (Tetra Paraffin Phenol) Phthalate

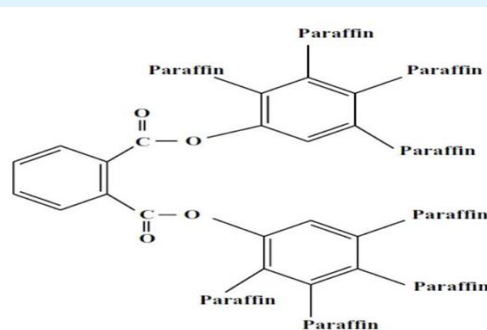

Esterification of Styrene-Maleic Anhydride Copolymer as Pour Point Depressant

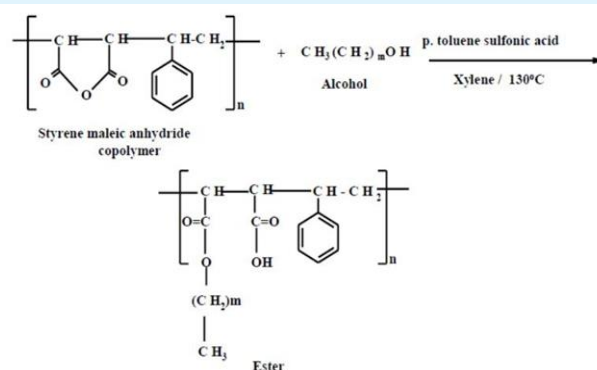

This copolymer by using docosanol as an alcohol and in concentration 0.0625% give very good result as pour point depressant ≥ -24 [10,14].

Mechanism of Pour Point Depressant

When oil subjected to very low temperatures (freeze) may undergo changes in their physical properties:-

1. Solidification but without precipitation of a solid phase;
2. Solidification with precipitation of a solid phase [25-27]. This solid phase may be according to size divided to

- a) Macrocrystals of paraffins which cause total solidification of oil.
- b) Microcrystals of wax which swell, forming a crystalline structure trapping a significant volume of oil [10, 14], so pour point depressant mechanism in simply way it means modify wax crystal formation to reduce interlocking at low temperatures and increase mobility of wax crystal around the flexible pour point depressants allowing the oil to continue to flow by adsorbed this type of additives on the wax crystals and inhibit the growth of a lattice interlocking network [1, 13, 15].

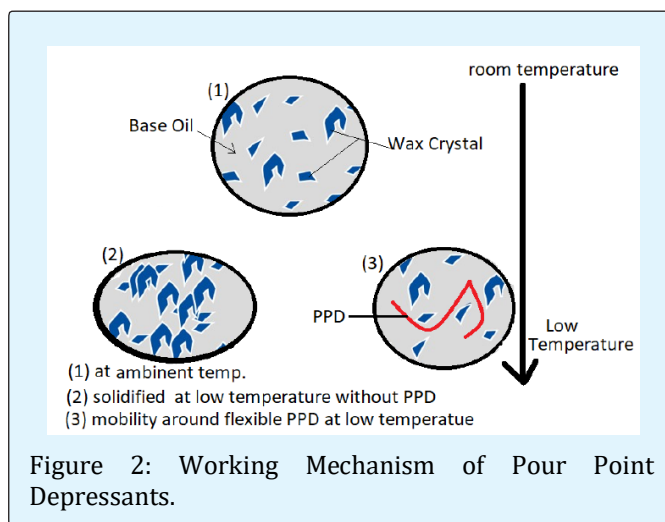

References

1. Ichiro Minami (2017) Molecular Science of Lubricant Additives. Appl Sci 7(445): 1-33.
2. Alphonse S (1968) Motor Oils and Engine Lubrication. 2nd (Edn.).
3. Abdel-Azim A, Abdel-Azim, Malcolm B Huglin (1983) Viscometric behaviour of polystyrene in tetralin/cyclohexane mixtures. Polymer 24: 1429-1433.
4. Bair S, Qureshi F (2003) The high pressure rheology of polymer-oil solutions. Tribology International 36(8): 637-645.
5. Pawlak Z (2003) Tribochemistry of Lubricating Oils. 1st (Edn.), Elsevier, UK, 45: 382.
6. Pedersen KS, Ronningsen HP (2003) Influence of Wax Inhibitors on Wax Appearance Temperature, Pour Point, and Viscosity of Waxy Crude Oils. Energy Fuels 17: 321-328.
7. Santos JCO, Santos IMG, Souza AG, Sobrinho EV, Fernandes VJ, et al. (2004) Thermoanalytical and rheological characterization of automotive mineral lubricants after thermal degradation. Fuel 83(17-18): 2393-2399.
8. Souza MSM (2000) Quime Deriv 382: 20.
9. Noria Corporation (2017) Lubricant Additives-A Practical Guide. Machinery Lubrication.
10. Kamal RS, Ahmed NS, Nasser AM (2017) Synthesis and Evaluation of Multifunctional Lube Oil Additives. Omniscryptum & Co.Kg, Noor Publishing.
11. Nasser AM, Ahmed NS, Kamal RS (2011) Preparation and Evaluation of Some Terpolymers As Lube Oil Additives. Journal of Dispersion Science And Technology 32(4): 616-621.
12. Mohamad SA, Ahmed NS, Hassanein SM, Rashad AM (2012) Investigation of polyacrylates copolymers as lube oil viscosity index improvers. Journal of Petroleum Science and Engineering 100: 173-177.
13. Amal Nassar, Ahmed NS (2003) Synthesis and Evaluation of Ethoxylated Polyesters as Viscosity Index Improvers and Pour Point Depressants for Lube Oil. International Journal of Polymeric Materials and Polymeric Biomaterials 52(9): 821-832.
14. Abdel Azim AAA, Nassar AM, Ahmed NS, El Kafrawy AF, Kamal RS (2009) Multifunctional Additives Viscosity Index Improvers Pour Point Depressants and Dispersants for Lube oil. Petroleum Science and Technology 27(1): 20-32.
15. Ahmed NS, Nassar AM, Nasser RM, Khattab AF, Abdel Azim AAA (2008) Synthesis and Evaluation of Some Polymeric Compounds as Pour Point

- Depressants and Viscosity Index Improvers for Lube Oil. *Petroleum Science and Technology* 26(12): 1390-1402.
16. Machado ALC, Lucas EF, Gonzalez G (2001) Poly (ethylene-co-vinyl acetate) (EVA) as wax inhibitor of a Brazilian crude oil: oil viscosity, pour point and phase behavior of organic solutions. *J of Petroleum Science and Engineering* 32(2-4): 159-165.
 17. Zhang J, Wu C, Li W, Wang Y, Cao H (2004) DFT and MM calculation: the performance mechanism of pour point depressants study *Fuel* 83(3): 315-326.
 18. Zhang J, Wu C, Li W, Wu N (2005) Molecular dynamics simulation guiding the improvement of EVA-type pour point depressant *Fuel* 84(16): 2039-2047.
 19. Song Y, Ren T, Fu X, Xu X (2005) Study on the relationship between the structure and activities of alkyl methacrylate-maleic anhydride polymers as cold flow improvers in diesel fuels. *Fuel Processing Technology* 86(6): 641-650.
 20. Hipeaux JC, Born M, Durand JP, Claudy P, Lètoffè JM (2000) Physico-chemical characterization of base stocks and thermal analysis by differential scanning calorimetry and thermomicroscopy at low temperature *Thermochimica Acta* 348(1-2): 147-159.
 21. Xuhong G, Brian AP, John SH, Robert KP (2004) Crystallization of Long-Chain n-Paraffins from Solutions and Melts As Observed by Differential Scanning Calorimetry. *Macromolecules* 37(15): 5638-5645.
 22. Zhang J, Wu C, Li W, Wang Y, Han Z (2003) Study on performance mechanism of pour point depressants with differential scanning calorimeter and X-ray diffraction methods. *Fuel* 82(11): 1419-1426.
 23. Coutinho JAP, Cauphin C, Daridon JL (2000) Measurements and modelling of wax formation in diesel fuels. *Fuel* 79(6): 607-616.
 24. Zuo JY, Zhang DD, Ng HJ (2001) An improved thermodynamic model for wax precipitation from petroleum fluids. *Chem Engng Sci* 56(24): 6941-6947.
 25. Jukić A, Tomašek LJ, Janović Z (2005) Polyolefin and poly(alkyl methacrylate) mixed additives as mineral lubricating oil rheology modifiers. *Lubr Sci* 17(4): 431-449.
 26. Queimada AJN, Dauphin C, Marrucho IM, Coutinho JAP (2001) Low temperature behaviour of refined products from DSC measurements and their thermodynamical modelling. *Thermochim Acta* 372(1-2): 93-101.
 27. MiranteJoão FIC, Coutinho JAP (2001) Cloud point prediction of fuels and fuel blends. *Fluid Phase Equilib* 180(1-2): 247-255.

